

Effective Algorithm for Image Compression Using DCT

Abhay Bhatia

Assistant Professor Department of Computer Science and Engineering

Dev Bhoomi Group of Institutions Saharanpur

Email: dhawan.abhay009@gmail.com

Abstract:

The issue of minimizing the quantity of data needed to represent the digital image is tackled via image compression. The process of compression involves eliminating one or more of the three fundamental data redundancies. There are three types of redundancy in images: (1) coding redundancy, which occurs when less-than-ideal code words are employed; (2) interpixel redundancy, which arises from correlations between pixels; and (3) psycho visual redundancy, which is caused by data that the human visual system ignores. Under the restriction that each source symbol be coded one at a time, Huffman codes have the fewest code symbols per source symbol feasible. Therefore, Huffman coding aids in image data compression when paired with the Discrete Cosine Transform technique for minimizing image redundancies. One type of transform coding is the Discrete Cosine Transform. The DCT is the foundation of the current JPEG standard. The top left corner of the image is where the DCT moves the most energy. Less energy or information is transferred to different locations. The DCT works best on photographs with smooth edges, such as those featuring human figures, and is rapid to compute. In contrast to the Fourier Transform, all of the DCT coefficients are real numbers. The image can be extracted from its transform representation using the Inverse Discrete Cosine Transform. The Discrete Wavelet Transform has become widely used in picture compression and signal processing. Wavelet-coding schemes' innate multi-resolution characteristics make them particularly well-suited for applications requiring scalability and acceptable deterioration. Recently the JPEG committee has released its new image coding standard, JPEG-2000, which has been based upon DWT.

Keywords- DCT, DWT, Huffman Coding, IDCT, Encoding, Decoding, JPEG-2

I. INTRODUCTION

Through the process of compression, the amount of capacity needed to store or the bit-rate needed to transmit computerized information can be decreased. The following are the reasons why compression is done: to shorten the amount of time needed for processing, transport, and storage. Image compression reduces a graphics file's byte count without sacrificing image quality. In order to solve problems, many apps require a significant number of photos. Digital photographs can be kept on disc, and image storage capacity is crucial. Because processing an image takes less time when there is less memory used. Reducing the quantity of data needed to depict a digital image is known as image compression [1]. The joint photographic expert group (JPEG) was developed in 1992, based on DCT. It has been one of the most widely used compression method [2]. The DCT hardware implementation for JPEG is straightforward, but at higher compression ratios, it is

impossible to ignore the observable "blocking artefacts" that span block boundaries. "False Contouring" reduces the quality of reconstructed images in photographs with gradually darker sections [3]. It is possible to display images at varied resolutions and get a higher compression ratio when using DWT-based coding. Another choice for image and video compression applications is the Forward Walsh Hadamard Transform (FWHT), which requires less computing power than the DWT and DCT algorithms. To capitalize on the distinct advantages of each well-known coding scheme, a hybrid algorithm—a novel method that combines the use of two transform techniques—has been designed. The Hybrid Transform Coding Technique was introduced by Yu and Mitra in reference [4]. Similar to this, Usama offers a scalable hybrid approach for picture coding that combines the Fourier transform and wavelets [5]. Singh et al. used a hybrid approach

that applies 5-level DWT decomposition to medical pictures in [6]. The scheme's higher level (5 levels DWT) makes it unsuitable for usage with current coding standards and necessitates significant processing resources. The techniques of DCT, DWT, and Hybrid DCT- DWT are covered in this section.

II. DISCRETE COSINE TRANSFORM

The input data points are represented by a DCT as the sum of cosine functions that oscillate at various frequencies and magnitudes. One dimensional DCT and two dimensional DCT are the two primary forms of DCT. The 2D DCT for an $N \times N$ input sequence can be defined as follows [7]:

$$D_{DCT}(i, j) = \frac{1}{\sqrt{2n}} B(i)B(j) \sum_{x=0}^{N-1} \sum_{y=0}^{N-1} M(x, y) \cdot \cos \left[\frac{2x+1}{2N} i\pi \right] \cos \left[\frac{2y+1}{2N} j\pi \right] \quad (1)$$

$$\text{Where } B(u) = \begin{cases} \frac{1}{\sqrt{2}} & \text{if } u = 0, \\ 1 & \text{if } u > 0 \end{cases}$$

The input data of size $x \times y$ is denoted by $M(x, y)$. After splitting the input image into 8×8 blocks, the 8-point 2-D DCT is carried out. Following that, an 8×8 quantization table is used to quantize the DCT coefficients. As indicated by equation (2), quantization is accomplished by dividing each element of the original data matrix that has been transformed by its corresponding element in the quantization matrix Q , then rounding to the closest integer value:

$$D_{quant}(i, j) = \text{round} \left\{ \frac{D_{DCT}(i, j)}{Q(i, j)} \right\} \quad (2)$$

After that, the proper scale factor is used to achieve compression. The data is then rescaled and de-quantized in order to be rebuilt. The inverse DCT is then used to transform the de-quantized matrix back. The entire process is depicted in Fig. 1.

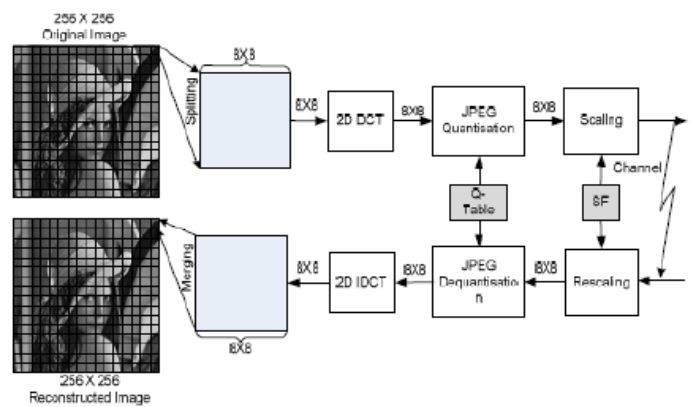

Figure 1:- Block Diagram of JPEG Based DCT scheme

A. Two Dimensional Discrete Cosine Transformation

Due to its almost ideal results when compared to the statistically optimal Karhunen-Loeve transform, the Two Dimension Discrete Cosine Transform (2D DCT) has grown in popularity for numerous image compression applications [12]. Because the 2D DCT requires a lot of processing, high speed, high throughput, and low latency computer architectures are highly desired. Owing to the substantial computational demands, the design of the 2D DCT processor has focused on compact, nonoverlapping blocks, usually measuring 8 by 8 or 16 by 16. Numerous 2D DCT methods have been put out in an effort to reduce computational complexity and boost throughput and operational speed. The two-dimensional DCT can be treated as a composition of two 1D DCT along each dimension. The formal definition is

$$X(l, m) = \sum_{i=0}^{N-1} \sum_{j=0}^{N-1} x(i, j) \cdot C_{li} C_{mj} \quad (3)$$

Where $x(i, j)$ is a value of the image element or the pixel which is located at the coordinates i, j . $X(l, m)$ is the 2D DCT coefficient at the position (l, m) and can be computed using the Eq. 1. Index take values $l, m = 0, 1, \dots, N-1$. The multiplication of 2D DCT base functions $C_{li} \cdot C_{mj}$ can be defined as

$$C_{li} C_{mj} = \cos \left[\frac{\pi}{N} \left(i + \frac{1}{2} \right) l \right] \cdot \cos \left[\frac{\pi}{N} \left(j + \frac{1}{2} \right) m \right] \quad (4)$$

The result of the 2D DCT is a square of frequency components when an 8x8 image block is taken into consideration and the upper left corner is treated as the position of (0,0). One DC coefficient, X(0,0), is present at the zero coordinates. The signal's most crucial components are located close to this DC coefficient.

B. Three-Dimensional Discrete Cosine Transformation

For both JPEG and MPEG image and video compression techniques, 3D DCT is typically utilized. These techniques are not lossless, though. As more people seek higher compression ratios (CR), unnecessary data is eliminated, lowering the quality of the final image or video clip. The Three-Dimensional Discrete Cosine Transform (3D DCT) is a technique used in both approaches to generate a spatial frequency spectrum. The DCT matrix coefficients for low frequency components can be kept with less precision due to the varying sensitivity of human vision to changes in colour or brightness across wide areas compared to high frequency brightness variations. The MPEG video sequence can be viewed as a collection of 2D images, and 3D DCT can be used to compress each of these images. Additionally, 3D DCT can be used to compress several photos of the same size. Using the —video cube, a cube made up of $N \times N \times N$ video elements, this concept is different. It is possible to think of the three-dimensional DCT as a combination of three 1D DCT along each axis. The formal definition is

$$X(l, m, n) = \sum_{i=0}^{N-1} \sum_{j=0}^{N-1} \sum_{k=0}^{N-1} x(i, j, k) \cdot C_{li} \cdot C_{mj} \cdot C_{nk} \quad (5)$$

where the value of an image series or video cube element is denoted by $x(i, j, k)$. For instance, if an 8x8 block size is chosen for transformation, then 8 photos can be taken into consideration. The image's position in this setup is denoted by k . $X(l, m, n)$ is a 3D DCT coefficient at position l, m, n for the pixel located at coordinates (i, j, k) , and index values for $l, m, n = 0, 1, \dots, N-1$. It is possible to define the multiplication of the 3D DCT base function $C_{li}, C_{mj},$

$$\text{and } C_{nk} = \cos \left[\frac{\pi}{N} \left(i + \frac{1}{2} \right) l \right] \cdot \cos \left[\frac{\pi}{N} \left(j + \frac{1}{2} \right) m \right] \cdot \cos \left[\frac{\pi}{N} \left(k + \frac{1}{2} \right) n \right] \quad \text{as} \quad (6)$$

C. Quantization

Many of the higher frequency coefficients become zero as a result of the human eye's ability to eliminate a large amount of redundant information from the zone of higher frequency coefficients. This can be accomplished by dividing each frequency component by an appropriate constant and rounding the result to the nearest integer. The quantized can be computed with

$$X_4(l, m, n) = \frac{X(l, m, n)}{Q(l, m, n)} \quad (7)$$

Where $X(l, m, n)$ are the frequency coefficients before quantizing, $X_4(l, m, n)$ are the frequency coefficients after quantizing and $Q(l, m, n)$ are the quantizing coefficients. Because of the information lost when the coefficients are rounded, this operation results in lossy information, which means that these components cannot be retrieved during the decompression process. One benefit of doing this kind of process is that you end up with less data to store. The quantization cube needs to be established since it is required to choose which constant will be used to quantize each frequency component. The quality of the output video sequence and the compression ratio are determined by its segments.

D. Entropy Coding

One common technique for lossless data compression is entropy coding. The Huffman coding method, which is also utilized in JPEG and MPEG, is among the most widely used entropy coding techniques. In the instance of a film or collection of photos, the quantized cube, or data, needs to be rearranged in a zigzag pattern. It is referred to as a quantized block if it consists of just one image. Less data will need to be stored the more zeros there are in the straight line. As a result, it also affects the compression ratio at the end.

III. DISCRETE WAVELET TRANSFORM

In DWT, an image is represented by sum of wavelet functions, which are known as wavelets, having different location and scale. Discrete Wavelet Transform represents the data into a set of high pass (detail) and low pass (approximate) coefficients. Image is first divided into blocks of 32×32. Then each block is passed through two filters: in this the first level, decomposition is performed to decompose the input data into an approximation and detail coefficients. After obtaining the transformed matrix, the detail and approximate coefficients are separated as LL, HL, LH and HH coefficients. Then all the coefficients are discarded, except the LL coefficients that are transformed into the second level. These coefficients are then passed through a constant scaling factor to achieve the desired compression ratio. Following fig. 2 is an illustration of DWT. Here, $x[n]$ is the input signal, $d[n]$ is the high frequency component, and $a[n]$ is the low frequency component. For data reconstruction, the coefficients are rescaled and padded with zeros, and passed through the wavelet filters. We have used the Daubechies filters coefficients in this study [9]:

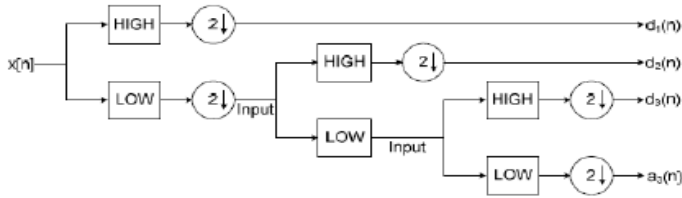

Fig 2: Block diagram of the 2- level DWT scheme C

IV. PERFORMANCE EVALUATION PARAMETERS

Two popular measures of performance evaluation are, Peak Signal to noise Ratio (PSNR) and Compression Ratio (CR). Which are described below:-

A. *PSNR*:- It is the most popular tool for the measurement of the compressed image and video. It is simple to compute. The PSNR in decibel is evaluated as follows [15]:

$$PSNR = 10 \log_{10} \frac{I^2}{MSE} \quad (3)$$

(8)

Where, I is allowable image pixel intensity level. MSE is mean squared error. It is another performance evaluation parameter of Image Compression Algorithms. It is an important evaluation parameter for measuring the quality of compressed image. It compares the original data with reconstructed data and then results the level of distortion. The MSE between the original data and reconstructed data is:

$$MSE = \frac{1}{MN} \sum_{i=1}^M \sum_{j=1}^N (A_{i,j} - B_{i,j})^2$$

(9)

Where, A = Original image of size $M \times N$
and B = Reconstructed image of size $M \times N$

B. *CR*:- It is a measure of the reduction of detail coefficient of data.

$$CR = \frac{\text{Discarded Data}}{\text{Original Data}}$$

(10)

In the process of image compression, it is important to know how much important coefficient one can discard from input data in order to preserve critical information of the original data.

V. LITERATURE SURVEY

Anil Kumar *et al.* in their paper two image compression techniques namely, DCT and DWT are simulated. They concluded that DWT technique is much efficient than DCT in quality and efficiency wise but in performance time wise DCT is better than DWT [1].

The workings of DWT and DCT transformations were presented by Swastik Das *et al.* They came to

the conclusion that image compression is crucial for real-time applications such as video conferencing where data is transmitted over a channel. Using the JPEG standard, DCT is used for mapping, which reduces inter-pixel redundancies; quantization is then used to reduce psycho visual redundancies; coding redundancy is then reduced by using an optimal code word with a minimum average length; all other methods remain the same. They also analyzed that DWT is more general and efficient than DCT [11].

The study conducted by Rupinder Kaur and colleagues compares various compression techniques, including Wavelet Transform, JPEG 2000, RLE (Run Length Encoding), and SPIHT (Set Partition in Hierarchical Trees), based on the compression ratio and quality. Based on the compression ratio and compression quality, these compression techniques are compared and categorized based on various medical photos. Their findings show that by using the SPIHT approach, they may obtain a greater compression ratio for MRI, ultrasound, CT scan, and iris images. Additionally, they note that compared to the JPEG method, the wavelet compression method for MRI images has a greater compression ratio and a better PSNR value for iris images. The iris and MRI images had about the same compression ratio. JPEG compression works better for CT scan images than PSNR and degree of compression than wavelet compression method [12].

Rehna et al. talked about various hybrid methods for compressing images. In this application, hybrid image coding refers to the process of combining two or more conventional techniques to improve on each one and provide higher compression ratio, better-quality reconstructed images. They also looked over previous years' worth of literature on hybrid image coding algorithms. They conducted a thorough analysis of the most important and current hybrid image coding techniques. And each strategy is shown to have advantages and disadvantages of its own. They also found that when wavelet-based hybrid approaches are used for image coding, high-quality reconstructed images can be achieved even at low bit

rates. They came to the conclusion that by integrating high performance coding techniques, the current standard picture compression technology may be improved by appropriate ways, such that the advantages of both techniques are fully exploited [13].

VI. OBJECTIVE OF THE STUDY

In terms of Peak Signal to Noise Ratio (PSNR), Mean Square Error (MSE), and Compression Ratio (CR), this study compares the effectiveness of three commonly used techniques: DCT, DWT, and Hybrid DCT-DWT.

VII. CONCLUSION AND FUTURE SCOPE

The results show that, when it comes to picture compression, the Hybrid DCT-DWT algorithm performs better than the two independent methods—DWT and DCT. PSNR, MSE, and compression ratio are the performance metrics that are taken into account while comparing performances. We discovered the different shortcomings and benefits of the strategies by comparing their performances using the previously given parameters and the JPEG image format. We discover that DCT performs significantly better than DWT in terms of performance, while DWT is more efficient in terms of quality. However, Hybrid DCT-DWT performs far better overall than the others. Based on the outcomes of the performance comparison, the researchers will have the option in the future to, the researchers will either be able to design a new transform technique or will be able to remove some of the deficiencies of these transforms.

REFERENCES

- 1] Anil Kumar Katharotiya, Swati Patel, Mahesh Goyani, “Comparative Analysis between DCT & DWT Techniques of Image Compression”. *Journal of*

- Information Engineering and Applications*, Vol. 1, No. 2, 2011.
- [2] R. K. Rao, P. Yip, “Discrete Cosine Transform: Algorithms, Advantages and Applications”. NY: Academic, 1990.
- [3] G. Joy, Z. Xiang, “Reducing false contours in quantized color images”. *Computer and Graphics*, Elsevier, Vol. 20, No. 2, 1996 pp: 231–242.
- [4] T.-H. Yu, S. K. Mitra, “Wavelet based hybrid image coding scheme”. *Proc. IEEE Int Circuits and Systems Symp*, Vol. 1, 1997, pp: 377–380.
- [5] U. S. Mohammed, W. M. Abd-elhafiez, “Image coding scheme based on object extraction and hybrid transformation technique”. *International Journal of Engineering Science and Technology*, Vol. 2, No. 5, 2010, pp: 1375–1383.
- [6] R. Singh, V. Kumar, H. K. Verma, “DWT-DCT hybrid scheme for medical image compression”. *Journal of Medical Engineering and Technology*, Vol. 31, No. 2, 2007, pp: 109–122.
- [7] R. K. Rao, P. Yip, “Discrete Cosine Transform: Algorithms, Advantages and Applications”. NY: Academic, 1990.
- [8] Suchitra Shrestha, “Hybrid DWT-DCT Algorithm for Image and Video Compression applications”, A Thesis, University of Saskatchewan, Electrical and Computer Engineering Dept., Canada, 2010. doi: 10.1109/ISSPA.2010.5605474
- [9] K. A. Wahid, M. A. Islam, S. S. Shimu, M. H. Lee, S. Ko, “Hybrid architecture and VLSI implementation of the Cosine-Fourier-Haar transforms”. *Circuits, Systems and Signal Processing*, Vol. 29, No. 6, 2010, pp: 1193–1205.
- [10] Suchitra Shrestha Khan Wahid (2010). “Hybrid DWT-DCT Algorithm for Biomedical Image and Video Compression Applications”. *Proceeding 10th*
- [11] Zhao W., Chellappa R., Rosenfeld A., Phillips P.J., *Face Recognition: A Literature Survey*, *ACM Computing Surveys*, Vol. 35, Issue 4, December 2003, pp. 399-458
- [12] Delac K., Grgic M., A Survey of Biometric Recognition Methods, *Proc. of the 46th International Symposium Electronics in Marine, ELMAR-2004*, Zadar, Croatia, 16-18 June 2004, pp. 184-193
- [13] Li S.Z., Jain A.K., ed., *Handbook of Face Recognition*, Springer, New York, USA, 2005
- [14] Delac, K., Grgic, M. (eds.), *Face Recognition*, I-Tech Education and Publishing, ISBN 978-3-902613-03-5, Vienna, July 2007, 558 pages
- [15] Rakshit, S., Monro, D.M., An Evaluation of Image Sampling and Compression for Human Iris Recognition, *IEEE Trans. on Information Forensics and Security*, Vol. 2, No. 3, 2007, pp. 605-612
- [16] Matschitsch, S., Tschinder, M., Uhl, A., Comparison of Compression Algorithms' Impact on Iris Recognition Accuracy, *Lecture Notes in Computer Science - Advances in Biometrics*, Vol. 4642, 2007, pp. 232-241
- [17] Funk, W., Arnold, M., Busch, C., Munde, A., Evaluation of Image Compression Algorithms for Fingerprint and Face Recognition Systems, *Proc. from the Sixth Annual IEEE Systems, Man and Cybernetics (SMC) Information Assurance Workshop*, 2005, pp. 72-78
- [18] Mascher-Kampfer, A., Stoegner, H., Uhl, A., Comparison of Compression Algorithms' Impact on Fingerprint and Face Recognition Accuracy, *Visual Communications and Image Processing 2007 (VCIP'07)*, *Proc. of SPIE 6508*, 2007, Vol. 6508, 650810, 12 pages
- [19] Elad, M., Goldenberg, R., Kimmel, R., Low Bit-Rate Compression of Facial Images, *IEEE Trans. on Image Processing*, Vol. 16, No. 9, 2007, pp. 2379-2383
- [20] Skodras A., Christopoulos C., Ebrahimi T., The JPEG 2000 Still Image Compression Standard, *IEEE Signal Processing Magazine*, Vol. 18, No. 5, September 2001, pp. 36-58