

Heartbeat Monitoring Using Arduino

R.Seetharaman¹, K.Aishwarya², S.Gayathridevi³, K.Raashmi⁴, R.Reshma⁵

1(Asst Professor, Department of Instrumentation and Control engineering,
Saranathan College of engineering)

2,3,4 ,5(UG Students, Department of Instrumentation and Control engineering,
Saranathan College of engineering)

Abstract:

In this paper, we have developed a device for monitoring the cardiac activities of a patient who has been affected by heart diseases. The heart beat sensor was used for monitor the heart rate(pulse rate) of a person. The measurement of biological parameters is very essential for maintaining a good health in heart patients. The finger tip heart beat sensor was used for measuring the heart rate of a person. The output of sensor was given to arduino. The arduino process the analog signal and send the data to the doctors mobile through the bluetooth module. It is an user friendly device which can be easily used by the cardiac patients.

Keywords- heart rate, arduino, bluetooth module, alarm.

I. INTRODUCTION

Electro Cardiography deals with the study of electrical activity of the heart muscle. The potentials originated in individual heart muscles are added to produce the ECG waveform. Electro Cardiogram is the recorded ECG wave pattern. It reflects the rhythmic electrical Depolarization and Repolarization of heart muscles. Any form of Arrhythmia can be easily diagnosed using ECG. The complete waveform is called Electrocardiogram with the labels PQRSTU indicating important diagnostic features. If the PR interval is more than 0.22s, the AV Block occurs. When the QRS complex duration is more than 0.1s, the Bundle Block occurs. Surface electrodes are used with the jelly type electrolyte between skin and electrode. Potential distribution changes in a regular and complex manner during each Cardiac cycle.

Prajakta A. Pawar proposed heart rate monitoring system using IR base sensor and arduino UNO. This system is used to monitor the heart beat of a person. The measured data is send to the doctor through the SMS with the help of GSM module. The digital signals from the sensors are given to the arduino. The heart beat sensor used here consist of LED which transmits red bright light and it acts as a transmitting part. A detector is used as a receiving part which absorbs signals from the LED. A finger is placed between the LED and the detector. From this they are calculating the number of times persons heart beats per minute[1].

Salomi S. Thomas , Mr.Amar saraswat, Anurag Shashwat , Dr. Vishal Bharti proposed sensing heart beat and body

used for monitoring the heart rate and the temperature sensor LM35 is used for measuring the temperature of a person. The digital signals from the sensors are given to the arduino microcontroller. This device is mainly used for measuring the mean arterial pressure (MAP) in about one minute and the accurate body temperature. The data is send to a mobile phone with the help of bluetooth module. The results will be displayed in the android[2].

G.Vijay kumar, A.Bharadwaja, N.Nikhil sai proposed a Temperature and heart beat monitoring system using IOT. The temperature and heart beat of a person is monitored in this paper. The sensors are used for receiving the signals from the physical environment and process the signal into digital output in the arduino 8051 microcontroller. The results are send to the doctor through the internet of things. In this paper, they have analysed the results of various age group of people[3].

Arulananth.T.S, B.Shilpa proposed a fingertip based heart beat motoring systems using embedded systems. In this system, they measured the heart rate by using the Photo Plethysmography(PPG) technique. It is a non-invasive method for measuring the blood volume in tissues of a person. It consists of a light source and detector for counting the heart rate. Through optical sensing mechanism, the fluctuation of blood around the fingertip is detected. The amplified signals are send to the serial ports of the arduino. Then the output is displayed in LCD[4].

II.HARDWARE SETUP

Heart beat sensor for detecting the heart beat of the body. Arduino for interfacing the sensor signal to the electrical output. Bluetooth setup for sending the message to the mobile phone. Alarm for detecting whenever the patient becomes abnormal.

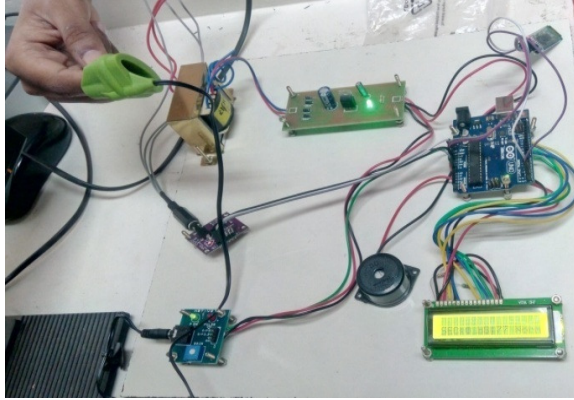

Figure.1

rate from the body of a patient. The sensors consist of a signal conditioning unit which eliminates the noise in the signals and amplifies the signal before giving the signals to the arduino. The arduino is programmed with embedded C language. As the normal heart rate of a person is between 60 and 100. If the range exceeds the normal limit, an alert signal will be produced. The range of heart beat is continuously displayed in the LCD. With the help of bluetooth module, the data is send as SMS to the doctors mobile.



Figure.3

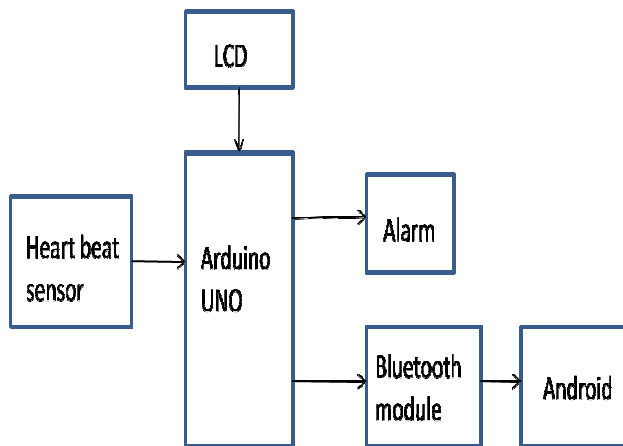

Figure.2

III.CARDIAC ACTIVITY MONITORING

A.HEART BEAT SENOR

The heart rate is a very essential parameter for monitoring the patients health. The heart rate is measured by counting the pulse of a person. A sensor is used for measuring the pulse

Process flow

Heart beat is calculated by counting the pulse for a period of seven seconds and it is multiplied with 10. If the value of heart beat is within 60 and 100, it is normal for an adult person at resting state. The change in this value is a symptom of heart disease.

B. BLUETOOTH MODULE

Bluetooth is a telecommunications industry specification that describes how mobile phones, computers, and personal digital assistants (PDAs) can be easily interconnected using a short-range wireless connection. A Bluetooth device uses radio waves instead of wires or cables to connect to a phone or computer. Bluetooth is low power, easy to use and low cost. HC-05 is an embedded Bluetooth serial communication module. The network ranges from two to eight connected devices. When a network is established, one device takes the role of the master while all the other devices act as slaves. The output data is continuously sent to the doctor's mobile with the help of the Bluetooth module.



Figure.4



Abnormal Heart beat



Normal Heart beat

C.ALARM

Buzzer or beeper is a signaling device. This device was based on an electromechanical system which was identical to an electric bell without the metal gong which makes the ringing noise. It most commonly consists of a number of switches or sensors connected to a control unit that determines if and which a preset value has lapsed sounds a warning in the form of a continuous or intermittent buzzing or beeping sound is produced. When the heart beat becomes abnormal alert signal has been produced from buzzer.

IV.EXPERIMENTAL RESULTS :

The heart beat was measured and the diagnosis of the result is shown in the table I. It is the general pulse rate for people which is used to know about the cardiac health of a person. The heart rate will vary based on their gender, age and their physical fitness

Table.1

Status	Heart rate(bpm)
Rest/Normal	60-100
Sleeping	40-50
Abnormal	>100

Table.2

Patient ID	Heart rate	Status
P1	40	Abnormal
P2	60	Normal
P3	98	Normal
P4	112	Abnormal
P5	120	Abnormal

This device is very helpful for elderly people for monitoring their health by themselves and to improve their quality of life. This device is simple to use and anyone can use it in an easy manner. The person can monitor their health before the occurrence of any risk . This device is cost effective and consumes very low power.

VI.FUTURE SCOPE

This paper can be taken into next level by adding additional parameters like ECG, EEG and BCG. This will help the elderly people and heart patients for monitoring their health.

VII.ACKNOWLEDGEMENT

Our project has come to this level with the help of our project guide Mr.Seetharaman and our project coordinators Dr.Mrs.Shanmugavalli and Mr.sathish kumar, we are whole heartedly thanking you.

VIII. REFERENCES

- [1] Heart Rate Monitoring System using IR base Sensor & Arduino uno. Prajakta A.Pawar.
- [2] Sensing Heart beat and Body Temperature Digitally using Arduino. Salomi S. Thomas, Mr. Amar Saraswat.
- [3] Temperature and Heart Beat Monitoring System Using IOT G.Vijay Kumar, A.Bharadwaja, N.Nikhil.
- [4] Fingertip based heart beat monitoring system using embedded systems. Arulananth.T.S, B.Shilpa.
- [5] The Design of Mobile EeG Monitoring System. Jihong Chai, Shenzhen Polytechnic.
- [6] A Wearable Wireless Sensor for Cardiac Monitoring.Jamal Ahmad Khan, Haroon Ali Akbar, Usama

Pervaiz.

[7] Souvik Das The Development of a Microcontroller Based Low HEART Rate counter for health care systems International journal of engineering trends and technology-volume4issue2013.

[8] G. Vijay Kumar, Dr. V. Valli Kumari, " Sliding Window Technique to Mine Regular Frequent Patterns in Data Streams using Vertical Format",IEEE International Conference on Computational Intelligence and Computing Research 2012.

[9] G. Vijay Kumar, Dr. V. Valli Kumari" Incremental Mining for Regular Frequent Patterns in Vertical Format", International Journal of Engineering and Technology, Volume 5, Issue 2, 2013.

[10]G. Vijay Kumar, Dr. V. Valli Kumari "MaRFI: Maximal Regular Frequent Itemset Mining using a pair of Transaction Ids",International Journal OF Computer Science and Engineering Technology, volume 4 No. 7,2013